

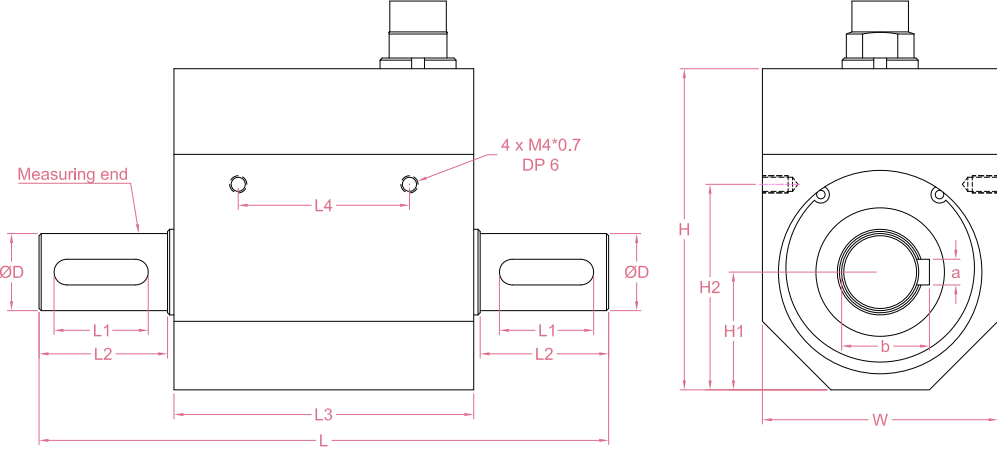

Dimensions in "mm"

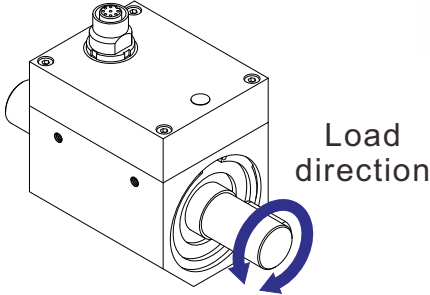

Torque capacity	Speed range	L	H	W	D	L1	L2	L3	L4	H1	H2	a	b
5/10/20/30/50/100 Nm	0~8000RPM	133	75	55	18	24	30	70	40	27.5	48	6	20.5
200/300/500 Nm	0~6000RPM	144	85	65	28	30	35	70	46	32.5	57	8	31



Specifications	
Torque Capacity	5/10/20/30/50/100/200/300/500 Nm
Excitation	12 or 24V DC
Rated Output	Refer to ordering part No.
Sampling Rate	500Hz
Nonlinearity	±0.2% F.S.
Hysteresis	±0.2% F.S.
Nonrepeatability	±0.2% F.S.
Creep(5min)	±0.1% F.S.
Safe Torque Limit	150% F.S.
Breaking Torque	200% F.S.
Operating Temp.	-10...+60°C
IP Rating	IP40
Element Material	Stainless steel
Housing Material	Aluminum alloy
Cable	Ø6*5000mm with mating connector

• LCS reserves the right to modify its design and specifications without notice





Cable Options

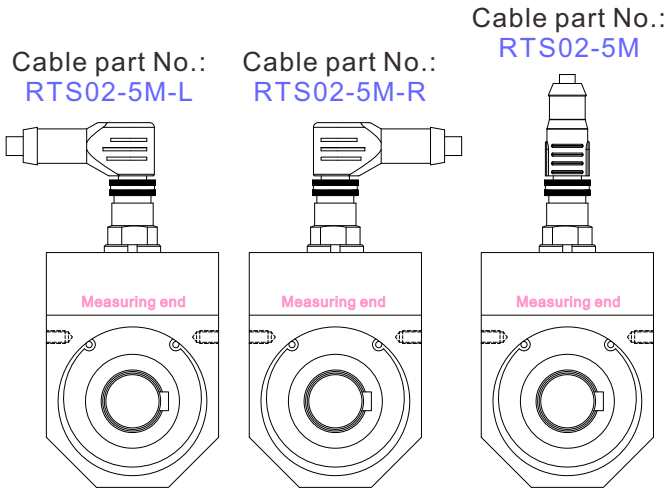

Display Options

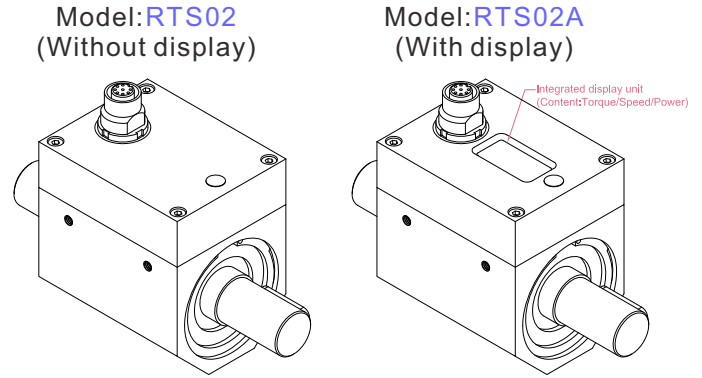

Ordering part No.

Torque Measurement Only				
Ordering part No.: Model - Torque capacity - Code				
Model	Torque cap. (Nm)	Code	Power supply	Torque output
RTS02 RTS02A	5 10 20 30 50 100 200 300 500	A	24V DC	-3.3-3.3V
		B		0-1.65-3.3V
		C		-5-5V
		D		0-2.5-5V
		E		-10-10V
		F		0-5V-10V
		G	12V DC	4-12-20mA
		H		-3.3-3.3V
		I		0-1.65-3.3V
		J		-5-5V
		K		0-2.5-5V
		L		4-12-20mA

Example: **RTS02-100-C** means:
Model: RTS02(Without display unit)
Power supply: 24V DC
Torque channel: -100Nm~100Nm VS -5-5V

Torque And Speed Measurement						
Ordering part No.: Model - Torque capacity - Speed capacity - Code						
Model	Torque cap. (Nm)	Speed cap. (RPM)	Code	Power supply	Torque output	Speed output
RTS02 RTS02A	5 10 20 30 50 100 200 300 500	0~100Nm: 0~8000	A	24V DC	-3.3-3.3V	0-3.3V
			B		0-1.65-3.3V	
			C		-5-5V	0-5V
			D		0-2.5-5V	
			E		-10-10V	0-10V
			F		0-5V-10V	
		G	200~500Nm: 0~6000	4-12-20mA	4-20mA	
		H		12V DC	-3.3-3.3V	0-3.3V
		I			0-1.65-3.3V	
		J			-5-5V	0-5V
		K			0-2.5-5V	
		L			4-12-20mA	4-20mA

Example: **RTS02A-100-8000-C** means:
Model: RTS02A(With integrated display unit)
Power supply: 24V DC
Torque channel: -100Nm~100Nm VS -5-5V
Speed channel: 0~8000RPM VS 0-5V

Wiring code	
Red	Power+
Black	Power-
Green	Torque output+
White	Torque output-
Yellow	Shield

Wiring code	
Red	Power+
Black	Power-
Green	Torque output+
Yellow	Speed output+
White	Output-
Bold Yellow	Shield

Order example:

Sensor: 1 x **RTS02A-50-6000-E**
Cable: 1 x **RTS02-5M-L**

Email to sales@loadcellsensor.com for a quote

